

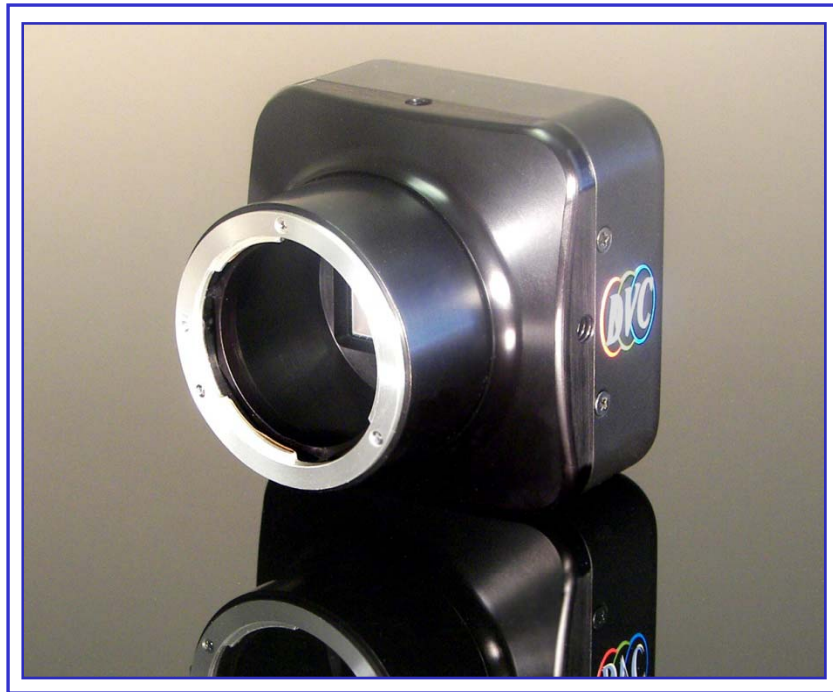

Features

- High QE CCD: >45% @500nm
- 16-Megapixel Resolution
- Interline, Progressive Scan CCD
- 12-Bit Digitization
- Single or Dual-tap Readout: 40 and 20 MHz
- Low Read Noise
- "F" Lens Mount
- High Signal to Noise Ratio
- Variable, On-chip Region of Interest and Binning
- No Mechanical Shutter
- Flexible Exposure and Readout Modes
- Software and External Asynchronous Triggers
- DVCView™: Image Capture and Control Software
- Windows/Linux API
- CE / UL / CUL / FCC Certified
- One-piece Optical Coupling with Internal Light Baffle



Description

The DVC-16000M is a 16-megapixel, high sensitivity digital camera that utilizes the Kodak KAI-16000 progressive-scan, interline CCD sensor. With 7.4 micron square pixels, very low noise, and a peak quantum efficiency of 45%, the DVC-16000M is the camera of choice for demanding scientific and industrial applications.

The DVC-16000M has four basic operating modes: streaming overlapped exposure, streaming non-overlapped exposure, edge-triggered single-frame snapshot, and variable pulse-width exposure.

The DVC-16000M is fully supported in our multi-platform SDK, which enables the streamlined integration of all DVC products into any system. The DVCView™ real-time viewing and image capture application also provides complete support for the DVC-16000M.

SPECIFICATIONS

DVC-16000M

CCD

KAI-16000 progressive scan interline CCD

Active Pixels	4872 X 3248
Pixel Size	7.4 μm X 7.4 μm (sq. format)
Imager Size	43.3mm (diagonal)
Aspect Ratio	3:2
Peak QE	>45%
Full Well	30,000e- @ 20 MHz 20,000e- @ 40 MHz

Digital Video

I/O	12-bit dual-port Camera Link			
A/D Converter 1 A/D Converter 2	12-bit single or dual-port, 20 or 40 MHz			
Read Noise	14e- @ 20 MHz			
Binning selected examples, dual-port frame rates		20MHz	40MHz	
	1X1	4872 X 3248	2.0	3.5
	2X2	2436 X 1624	3.5	5.5
	3X3	1624 X 1083	4.6	6.8
	4X4	1218 X 812	5.5	7.7
ROI selected examples, dual-port frame rates		20MHz	40MHz	
	2048 X 2048	3.0	4.8	
	1024 X 1024	4.8	7.0	
	512 X 512	7.0	9.1	
	256 X 256	8.9	11.6	

Electrical

Input Voltage	110/220 VAC 50/60 Hz
Power	<5 Watts

Mechanical

Size	3.25" (H) X 3.25" (W) X 3.11" (L)
Weight	18 ozs. (505 grams)
Lens Mount	F-mount with internal light baffle
Camera Mount	¼" X 20 Standard Tripod mount
Camera Connector	Camera Link....MDR-26
Power Connector	DB-9M

DVCView™ Interface

Camera Control

Software module, standard

Gain Control Range	35 dB
Offset Control (black)	0% to 6% in 256 steps
Exposure Range	85 μs to 1 hour



16000M

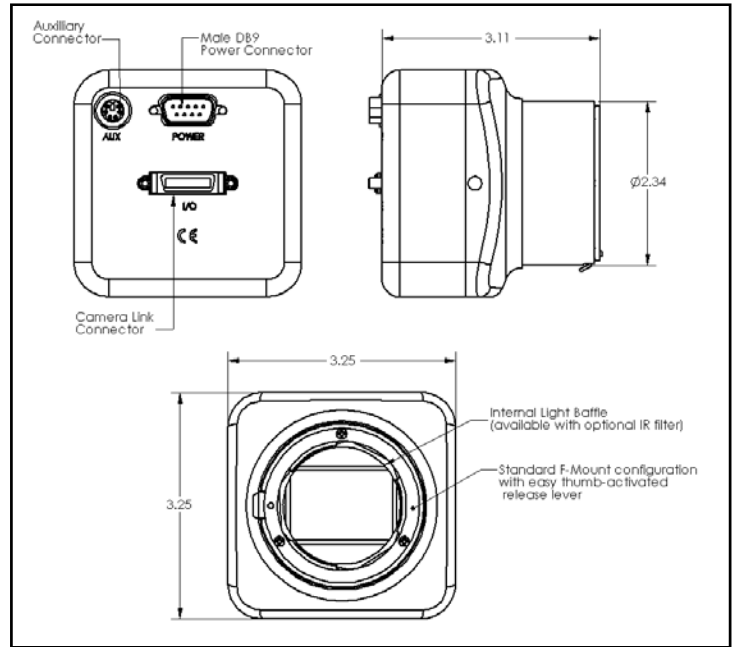

Switchmode Power Supply

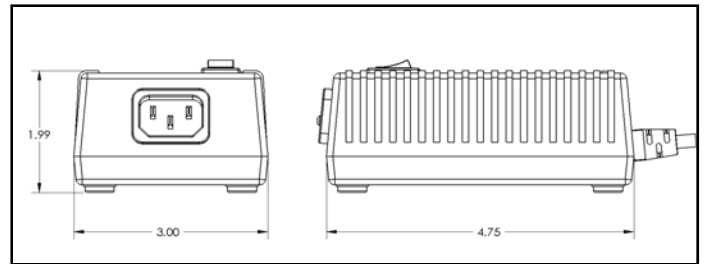

CCD Quantum Efficiency

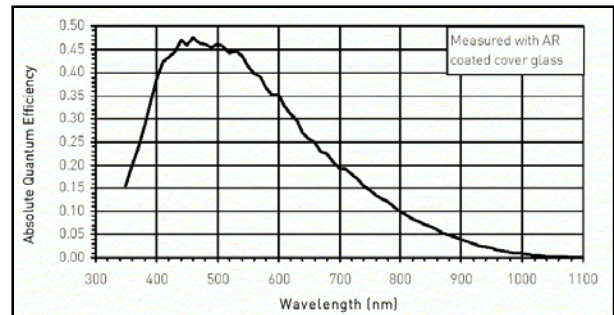

IR Filter Response

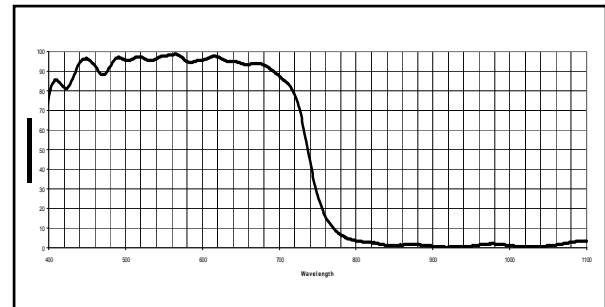

Address: 10200 Highway 290 West, Austin, TX 78736 Ph: 512-301-9564 Fax: 512-288-2961

Email: sales@dvcco.com website: www.dvcco.com

